

Инструкция по установке
UAZ Hunter (2003-)
UAZ 469 (1972-1985; 2010-2011)
UAZ 3151/31512 (1985-2013)
 Арт.: U63024



Тип шара - «Е»





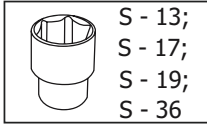
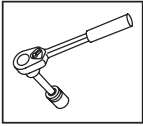



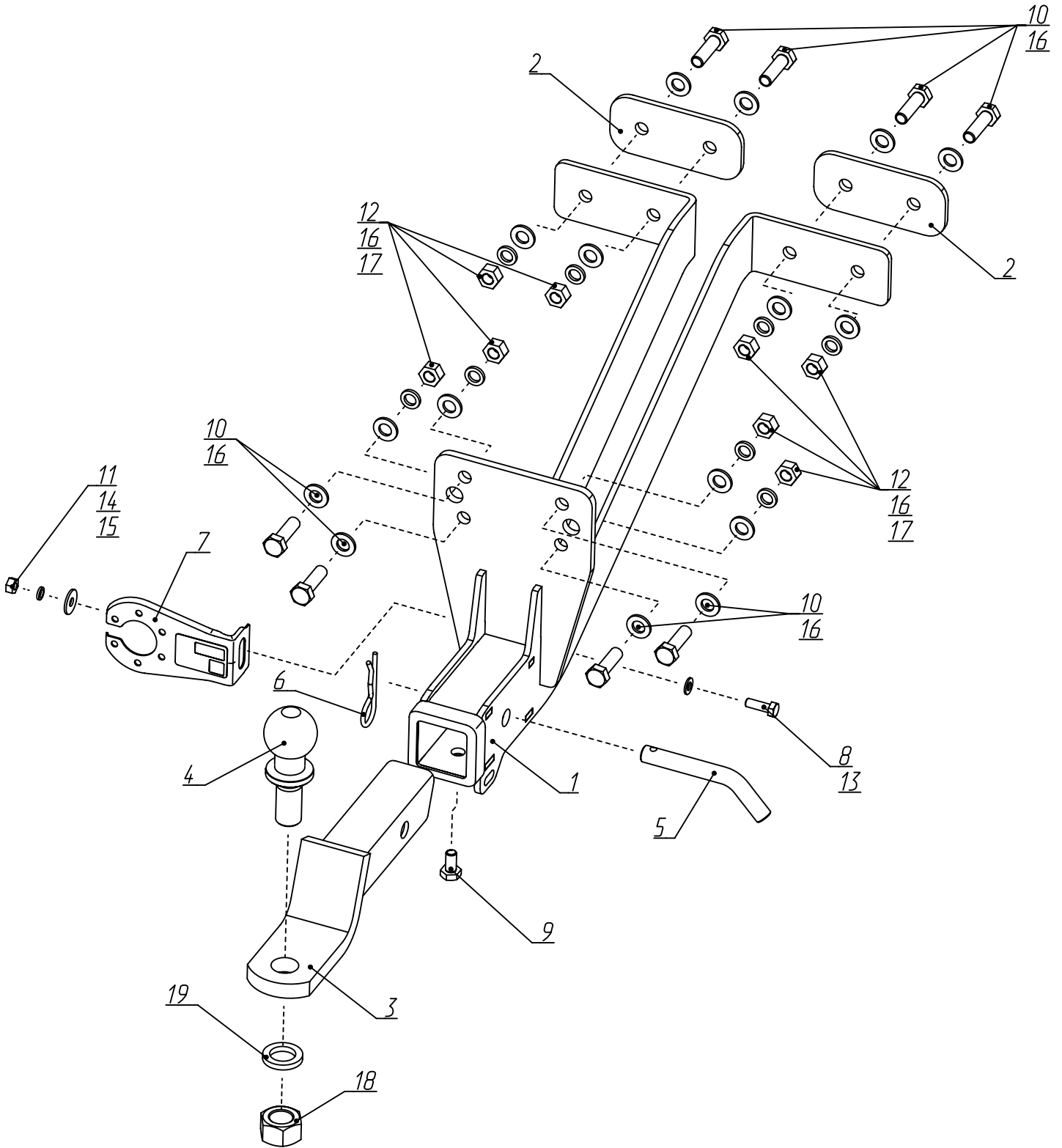

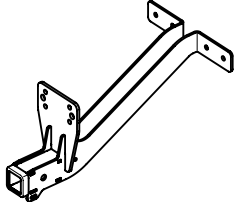
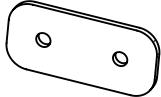
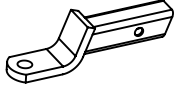
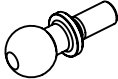
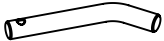

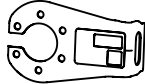

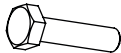
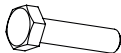
	 1500 kg	 100 kg	D = 9,2 kN						
$D \text{ (kN)} = \frac{\text{MAX kg} \times \text{MAX kg}}{\text{MAX kg}} \times 0,00981$	<table border="1"> <tr> <td data-bbox="975 1892 1329 2004">UAZ Hunter (2003-)</td> <td data-bbox="1329 1892 1495 2004"> <input checked="" type="checkbox"/> </td> </tr> <tr> <td data-bbox="975 2004 1329 2116">UAZ 469 (1972-1985; 2010-2011)</td> <td data-bbox="1329 2004 1495 2116"> <input checked="" type="checkbox"/> </td> </tr> <tr> <td data-bbox="975 2116 1329 2179">UAZ 3151/31512 (1985-2013)</td> <td data-bbox="1329 2116 1495 2179"> <input checked="" type="checkbox"/> </td> </tr> </table>			UAZ Hunter (2003-)	<input checked="" type="checkbox"/>	UAZ 469 (1972-1985; 2010-2011)	<input checked="" type="checkbox"/>	UAZ 3151/31512 (1985-2013)	<input checked="" type="checkbox"/>
UAZ Hunter (2003-)	<input checked="" type="checkbox"/>								
UAZ 469 (1972-1985; 2010-2011)	<input checked="" type="checkbox"/>								
UAZ 3151/31512 (1985-2013)	<input checked="" type="checkbox"/>								

Используемый инструмент:



S - 13;
S - 17;
S - 19;
S - 36

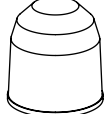

1	x1	Кронштейн	
2	x2	Пластина прижимная	
3	x1	Переходник	
4	x1	Шар	
5	x1	Штифт	
6	x1	Шплинт	
7	x1	Кронштейн под розетку	
8	x1	M8x25	
9	x1	M10x20	
10	x8	M12x1,25x40	
11	x1	Гайка 8	
12	x8	Гайка 12x1,25	
13	x1	Ø 8	
14	x1	Ø 8	
15	x1	Ø 8 увел.	
16	x16	Ø 12	
17	x8	Ø 12	
18	x1	Гайка 24	
19	x1	Ø24	
20	x1	Колпачок	



Закрепить кронштейн (1) к отверстиям А в задней части рамы автомобиля при помощи болтов М12х1,25х40 (10), шайб 12 (16), шайб 12 пружинных (17) и гаек М12х1,25 (12).



3



Затем закрепить кронштейн (1) к перекладине рамы автомобиля при помощи прижимных пластин (2), болтов М12х1,25х40 (10), шайб 12 (16), шайб 12 пружинных (17) и гаек М12х1,25 (12).

4



5



6



Установить кронштейн под розетку (7) на кронштейн (1) с помощью болта М8х25 (8), шайбы 8 (13), шайбы 8 пружинной (14), шайбы 8 увел. (15) и гайки М8 (11).

7

Установить переходник (3), закрепив с помощью штифта (5) и шплинта (6). Зафиксировать переходник болтом М10х20 (9) - фиксацию использовать только без нагрузки. Установить на переходник шар (4), закрепив гайкой М24 (18) с шайбой 24 пружинной (19).

8

Затянуть все резьбовые соединения. Моменты затяжки: М8=25 Нм, М10=47 Нм, М12=81 Нм, М24=95 Нм.