



Vehicle Model
Model Year
Part No.
Language
Rev. Date

Hyundai Palisade
 2025-
 P9F36AU000
 English
 10.03.2025

Accessory
Difficulty
Note

Skid Plate
 B
 Difficulty stated above reflects the minimum level of expertise required to install the accessory:
 (A) Customer
 (B) Dealer Technician
 (C) Master Technician or Specialist

Instructional Symbols / Definitions



Denotes warnings that may lead to serious physical injury or vehicle damage.



Denotes quality processes to be checked prior to moving to the next step.

Denotes personal protective equipment (PPEs) that may be required for a step. Examples of safety equipment icons noted below:



Denotes cautions to be taken to avoid physical injury or electronic component damage.



Denotes specific tools that are necessary to complete a step.



Mask



Glasses



Denotes cautions to be taken to avoid vehicle and component damage.



Denotes important information to be reviewed during the step.



Gloves



Hearing Protection

Basic Required Tools

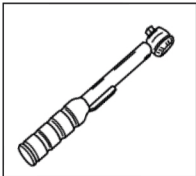

Torque Wrench



Ratchet

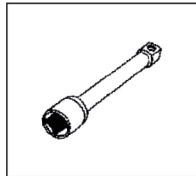

Extension

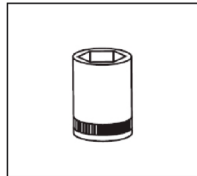

10mm Socket

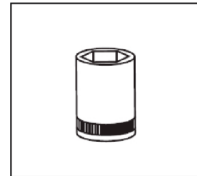

17mm Socket

Specialty Required Tools

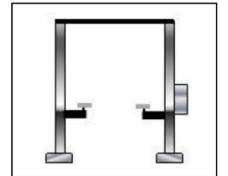

Vehicle Lift

Notes to the installer:

- 1) Read the entire Installation Instructions prior to beginning the installation of this accessory.
- 2) Make sure the vehicle is completely clean and dry in the area(s) the part is to be installed.
- 3) Ensure the vehicle is properly protected in the area(s) that the accessory is to be installed.
- 4) NEVER place tools on painted surfaces, seating surfaces, dash pad, console or floor carpet/mats.
- 5) Always wear appropriate personal protective equipment, including gloves, safety glasses, etc., when required.
- 6) Roll down the driver's window and adjust the power seats (if applicable) prior to disconnecting battery power, if needed.

Kit Overview

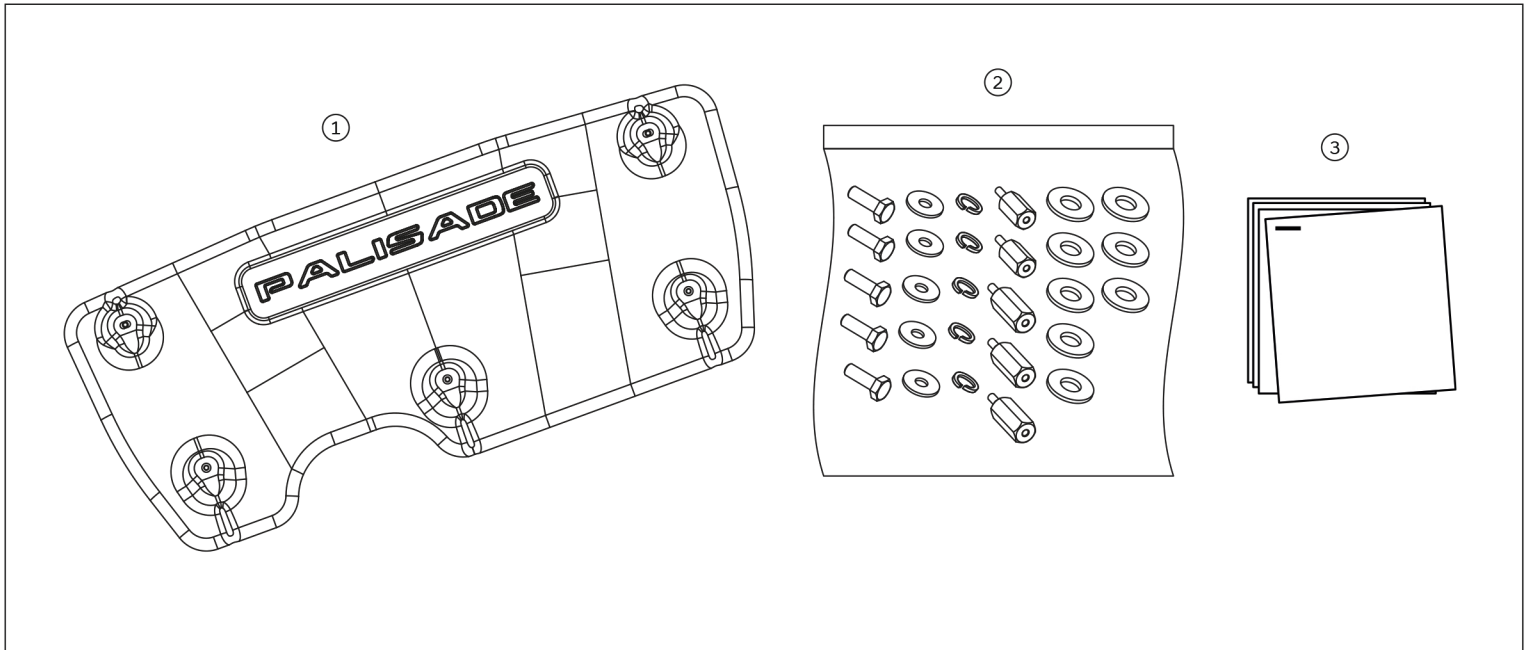

No.	Qty	Description
1	1	Skid Plate
2	1	Hardware Kit
3	1	Installation Instructions

Hardware Kit Contents

A	
5	Bolt (M6x20mm)

B	
5	Split Lock Washer 6

C	
5	Washer 6

D	
2	Standoff H-31

E	
3	Standoff H-38.6

F	
8	Washer 8

Follow instructions for proper placement of each component.

Hardware Total
28

1  Vehicle Lift

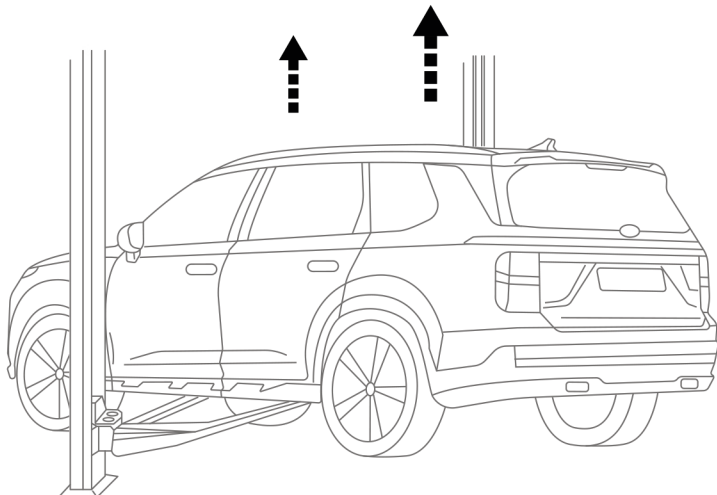

NOTE

A. Place vehicle on a vehicle lift.
B. Raise vehicle to desired working height to access the under body at the front of the vehicle.

WARNING: Adhere to Vehicle Lift safety standards.

2  Ratchet, Extension and 10mm Socket

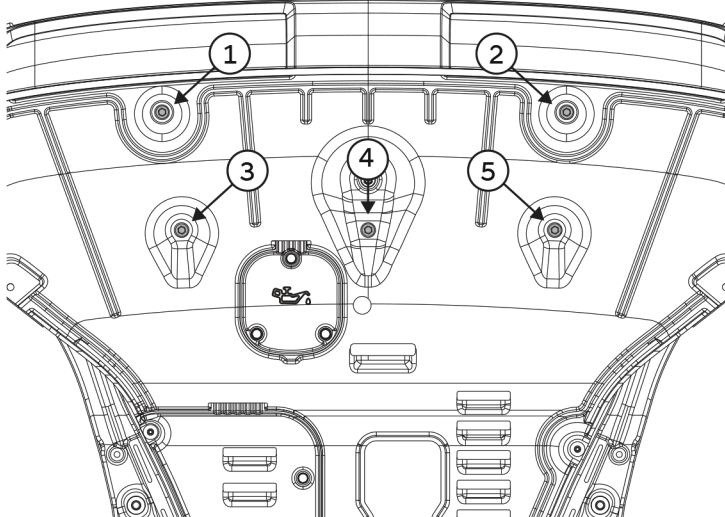

NOTE

A. Remove the five (5) factory bolts shown above and discard.

3  Ratchet, Extension, Torque Wrench and 17mm Socket

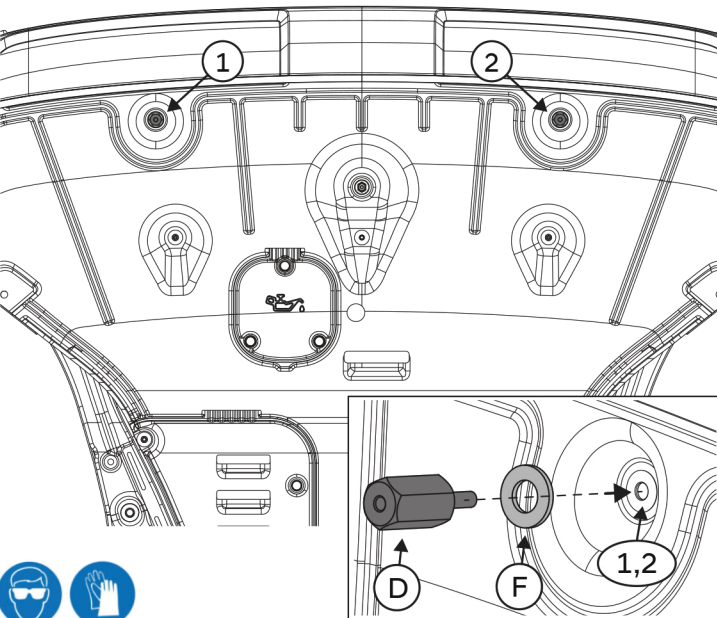

NOTE

A. Insert two (2) standoffs [D] with one (1) washers 8 [F] into the factory bolt locations [1] and [2] as shown above.
B. Torque the two (2) standoffs [D] to: **9.5N-m (0,97 kgf-m, 84.00 lbf-in)**

WARNING: Do NOT cross-thread or over-torque the standoffs.

4  Ratchet, Extension, Torque Wrench and 17mm Socket

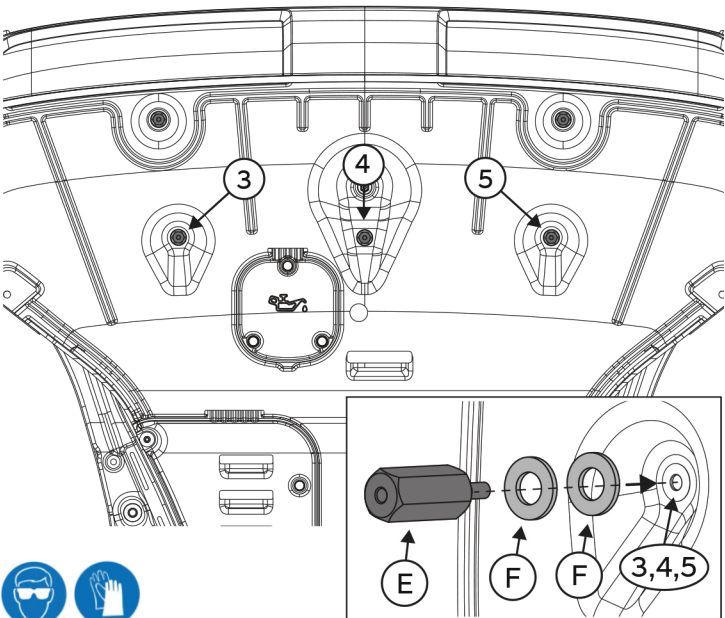

NOTE

A. Insert three (3) standoffs [E] with two (2) washers 8 [F] into the factory bolt locations [3], [4] and [5] as shown above.
B. Torque the three e(3) standoffs [E] to: **9.5N-m (0,97 kgf-m, 84.00 lbf-in)**

WARNING: Do NOT cross-thread or over-torque the standoffs.

5  Ratchet, Extension, Torque Wrench and 10mm Socket

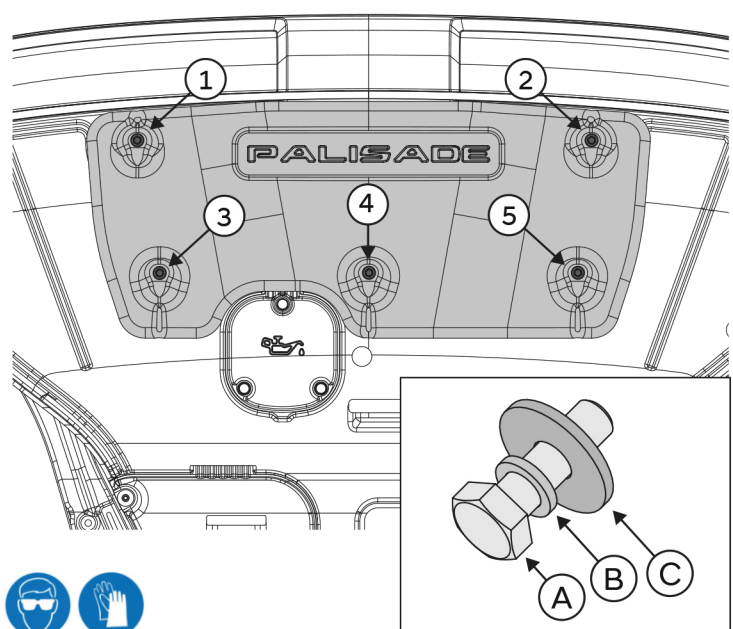

NOTE

- A. Preassemble the five (5) bolts [A] with a split lock washer 6 [B] and a fender washer enlarged 6 [C] as shown above.
- B. Raise the skid plate into position then insert and hand tighten the five (5) bolt and washers assemblies through the skid plate holes and into the standoffs previously installed.

 **Do NOT cross-thread the hardware.**

6  Ratchet, Extension, Torque Wrench and 10mm Socket

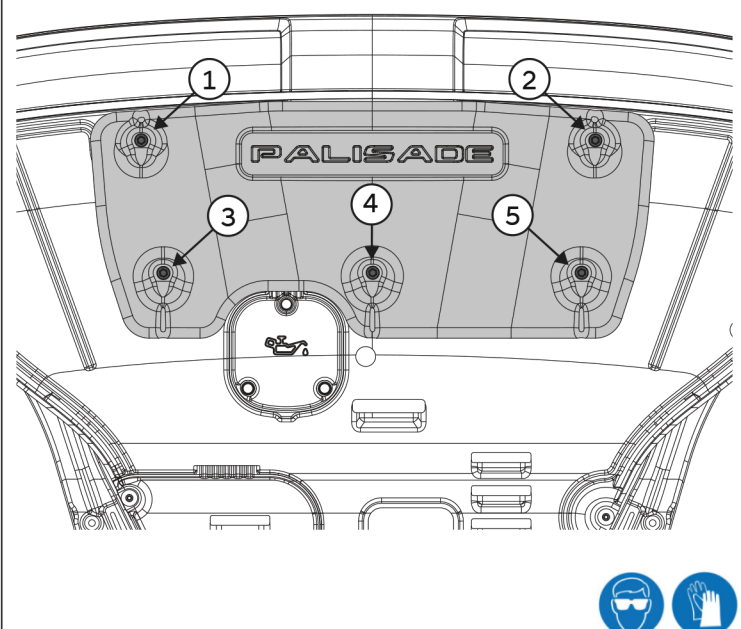

NOTE

- A. Torque all five (5) bolt and washers assemblies to: **9.5 N-m (0.97 kgf-m, 84.00 lbf-in).**

 **Do NOT over-torque the hardware.**

7  Vehicle Lift

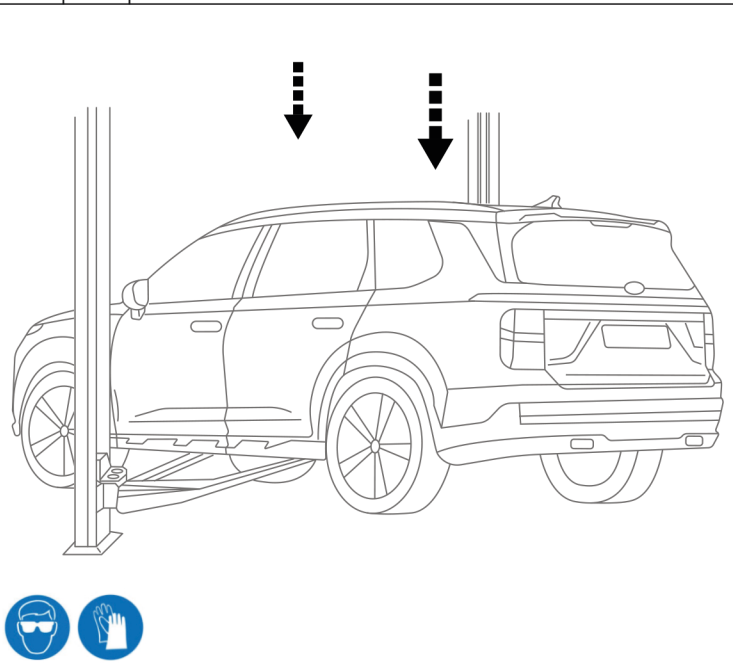



NOTE

- A. Lower the vehicle.
- B. Installation is complete.

 **WARNING: Adhere to Vehicle Lift safety standards.**

Visual Check

	Item to be Checked	Result
	Ensure all hardware is properly assembled and torqued.	All hardware is properly assembled and torqued.
	Check position of Skid Plate to make sure that it is positioned properly.	Skid Plate is properly installed.