











Инструкция по установке
HYUNDAI TUCSON
 2021-
KIA SPORTAGE
 2022-



Арт.: F.2314.003

 <p>MAX kg X</p>	 <p>2000 kg</p>	 <p>75 kg</p>	<p>D = 10,2 kN</p>				
$D \text{ (kN)} = \frac{\text{MAX kg} \times \text{MAX kg} \times \text{MAX kg}}{\text{MAX kg} \times \text{MAX kg}} \times 0,00981$  <p>MAX kg + MAX kg</p>	<table border="1"> <tr> <td data-bbox="957 1892 1316 2016"> <p>HYUNDAI TUCSON 2021-</p> </td> <td data-bbox="1316 1892 1498 2016">  <input type="checkbox"/> </td> </tr> <tr> <td data-bbox="957 2016 1316 2184"> <p>KIA SPORTAGE 2022-</p> </td> <td data-bbox="1316 2016 1498 2184">  <input type="checkbox"/> </td> </tr> </table>			<p>HYUNDAI TUCSON 2021-</p>	 <input type="checkbox"/>	<p>KIA SPORTAGE 2022-</p>	 <input type="checkbox"/>
<p>HYUNDAI TUCSON 2021-</p>	 <input type="checkbox"/>						
<p>KIA SPORTAGE 2022-</p>	 <input type="checkbox"/>						

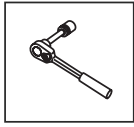

Вкрутить/выкрутить используя инструмент

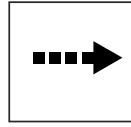

Движение

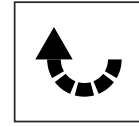

Поворот

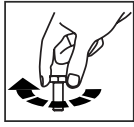



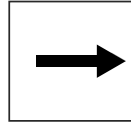





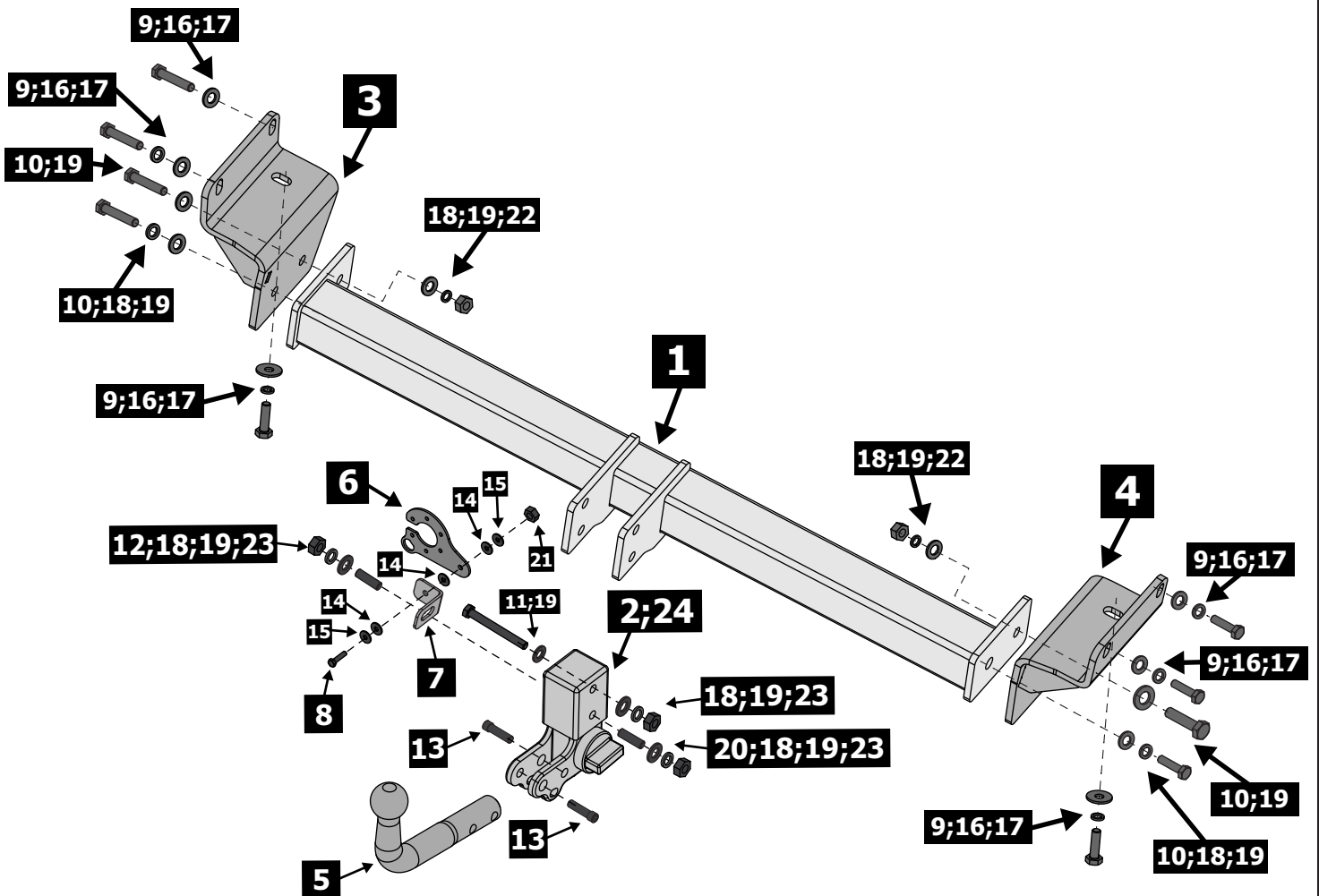
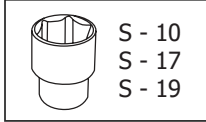
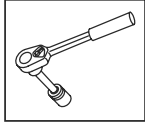

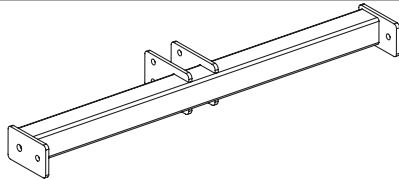
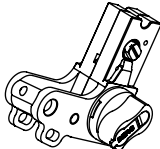
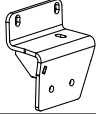
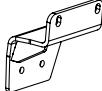
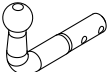





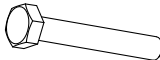

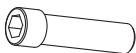

Вкрутить/выкрутить не затягивая



Расположение

Используемый инструмент:



1	x1	Балка	
2	x1	Вставка быстросъема	
3	x1	Кронштейн левый	
4	x1	Кронштейн правый	
5	x1	Крюк	
6	x1	Подрозетник	
7	x1	Уголок	
8	x1	M6x25	
9	x6	M10x1,25x35	
10	x4	M12x1,25x40	
11	x1	M12x100	
12	x1	Шпилька M12x35	
13	x2	M12x45	
14	x3	∅6 (полиамид)	
15	x2	∅6	
16	x6	∅10	
17	x6	∅10	
18	x7	∅12	
19	x10	∅12	
20	x1	Шпилька M12x30	
21	x1	M6	
22	x2	M12x1,25	
23	x3	M12	
24	x1	Ответная часть быстросъема	

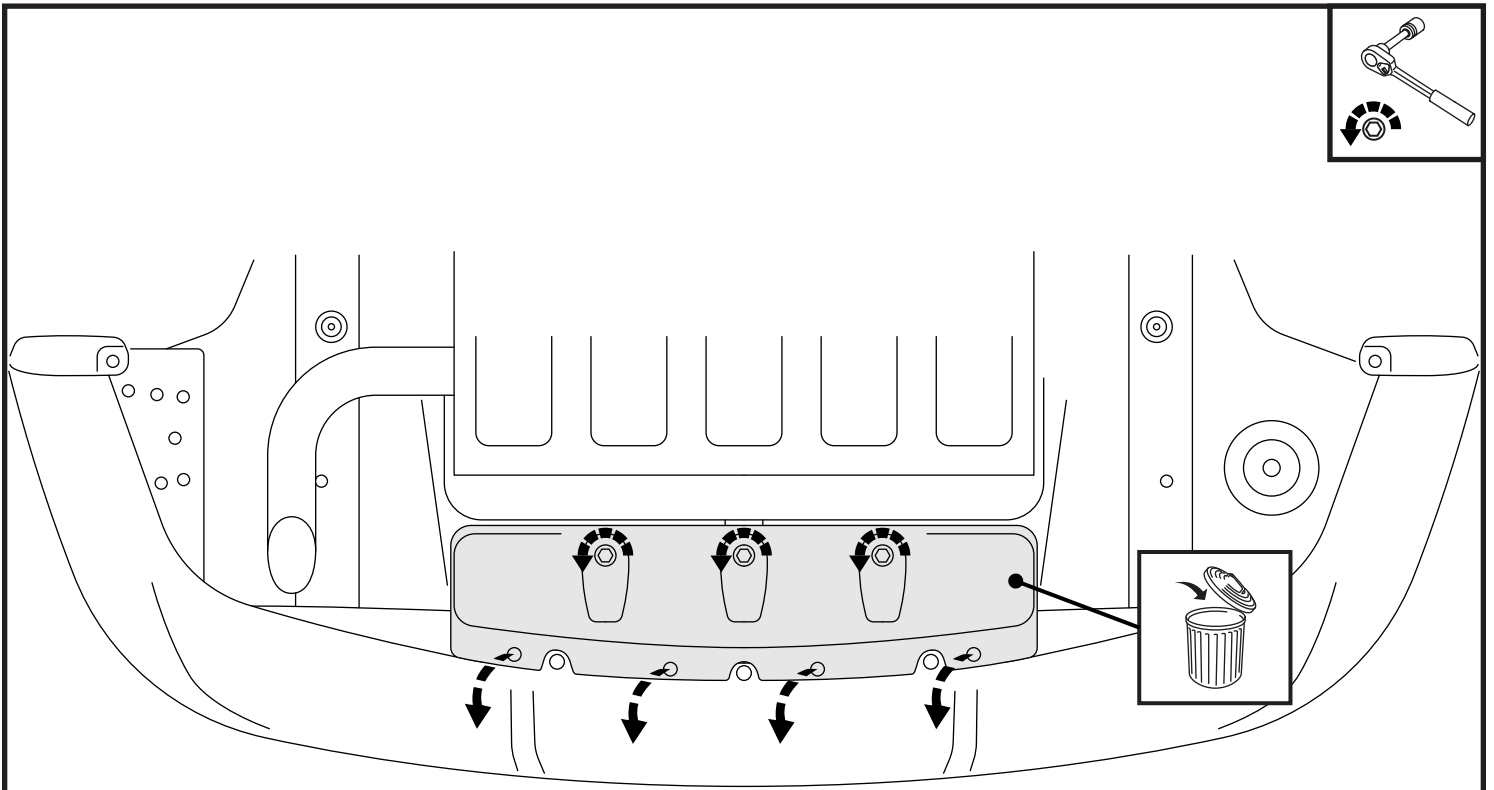

1

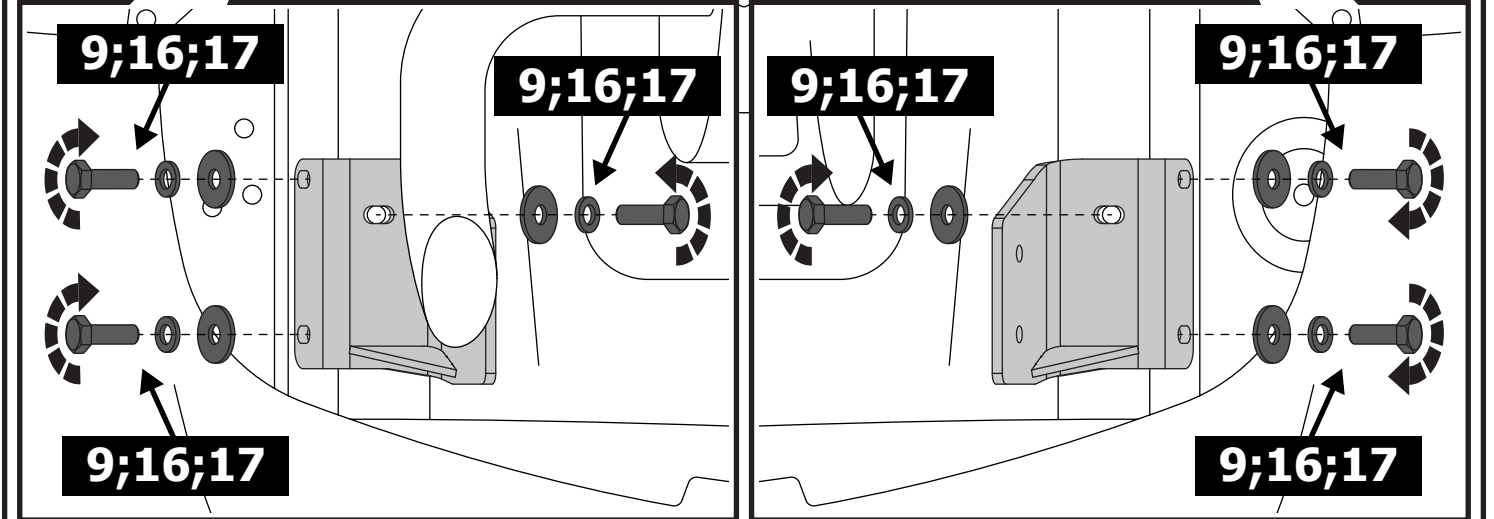
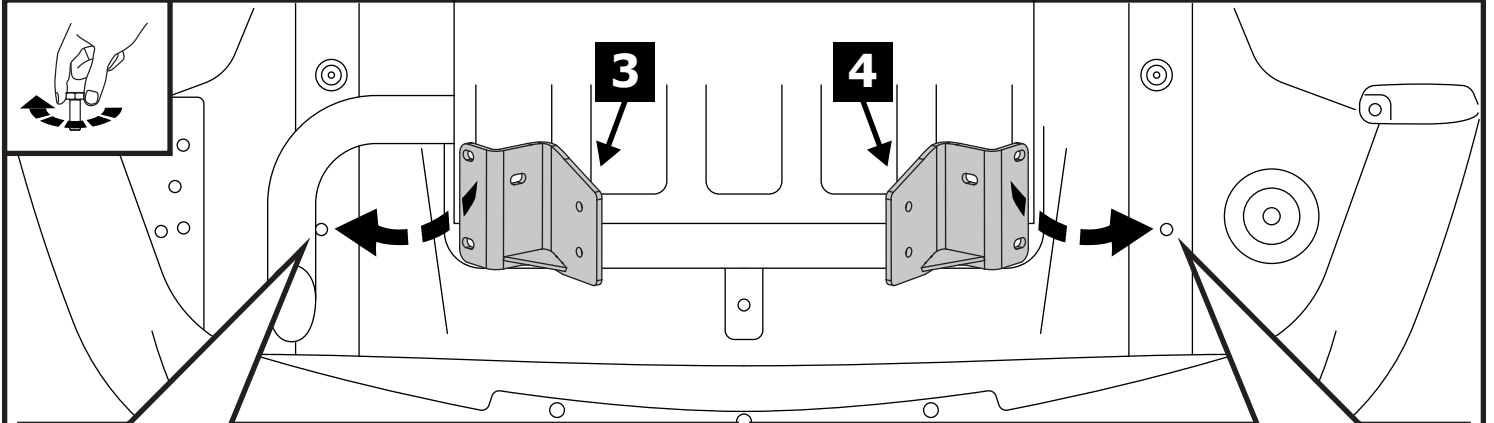

2

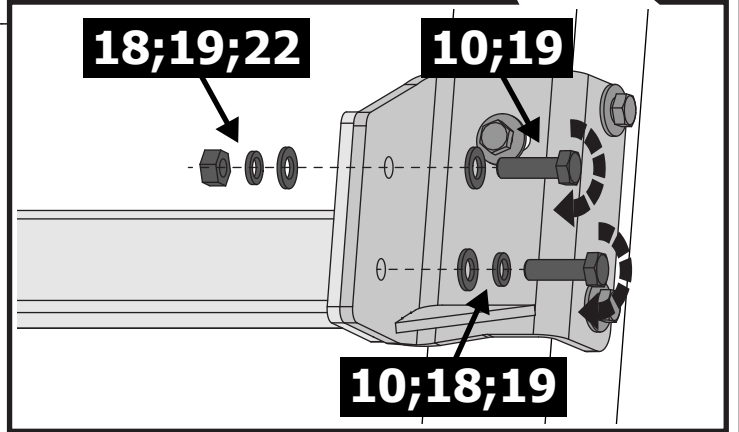
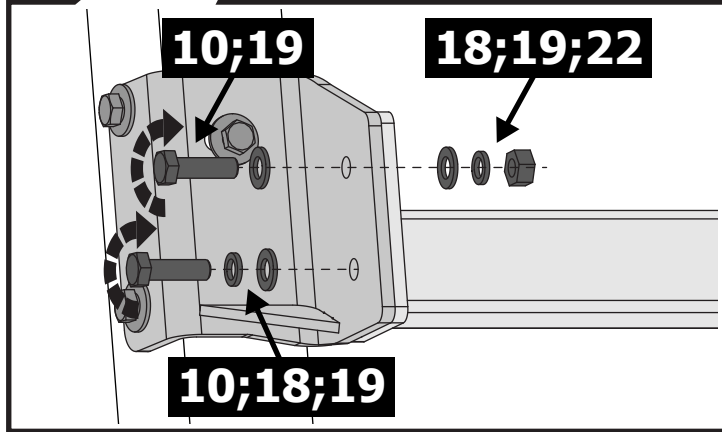
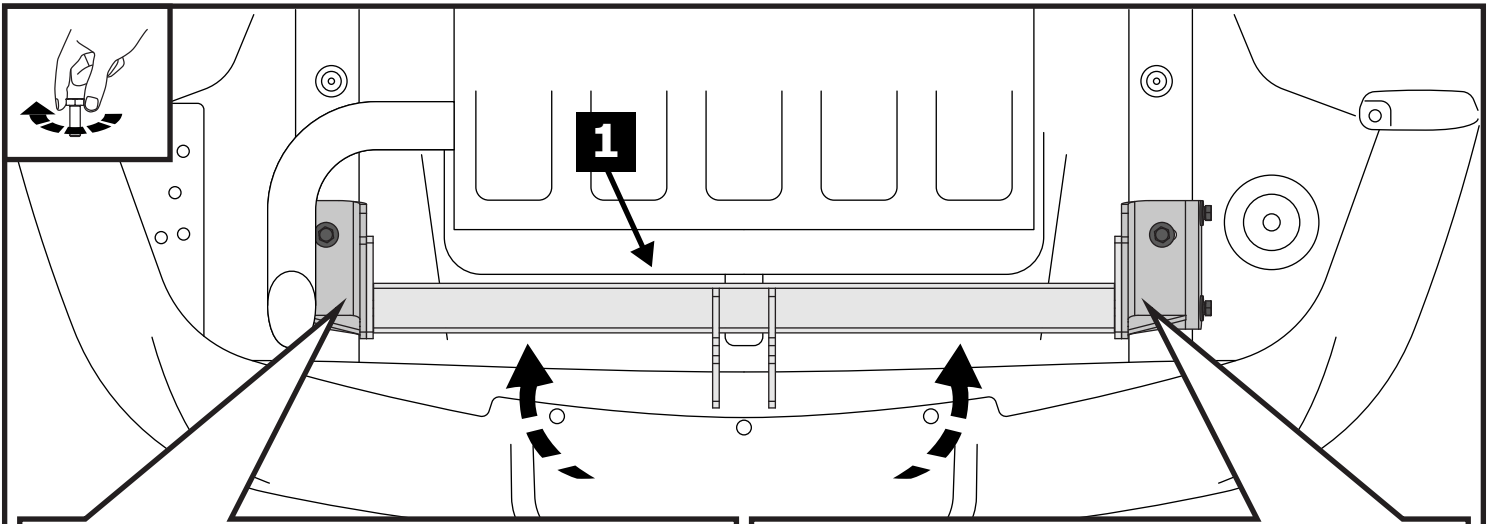

3

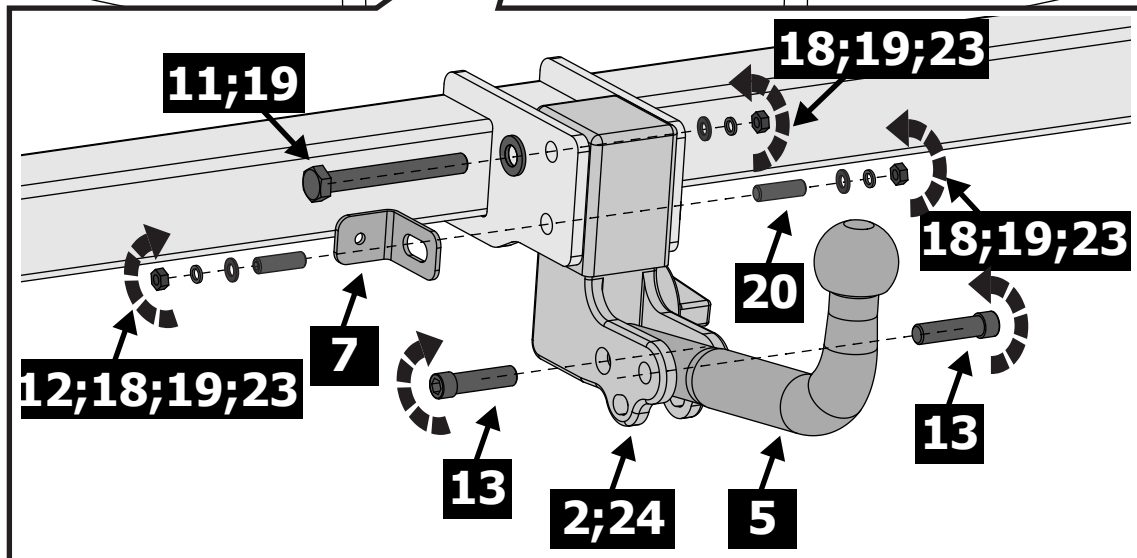
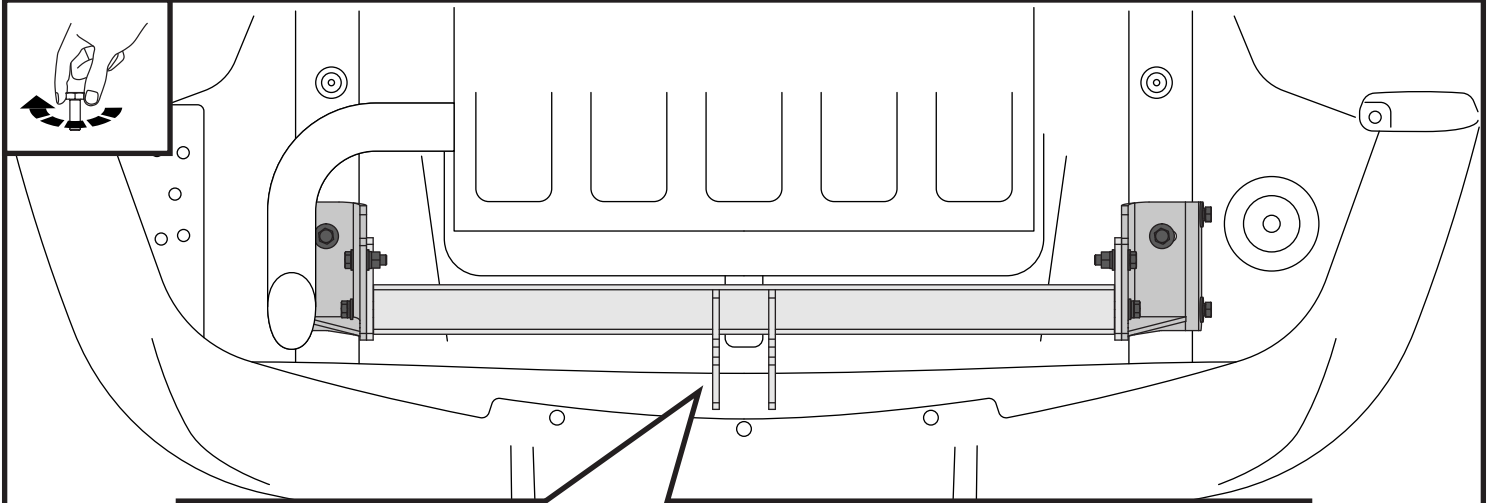

4

