

Инструкция по установке











Hyundai Tucson (2021-)

KIA Sportage (2022-)

Арт.: F. 2314.002



Тип шара - «Е»





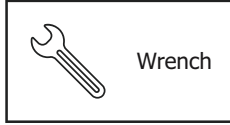
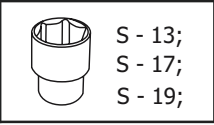
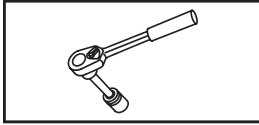



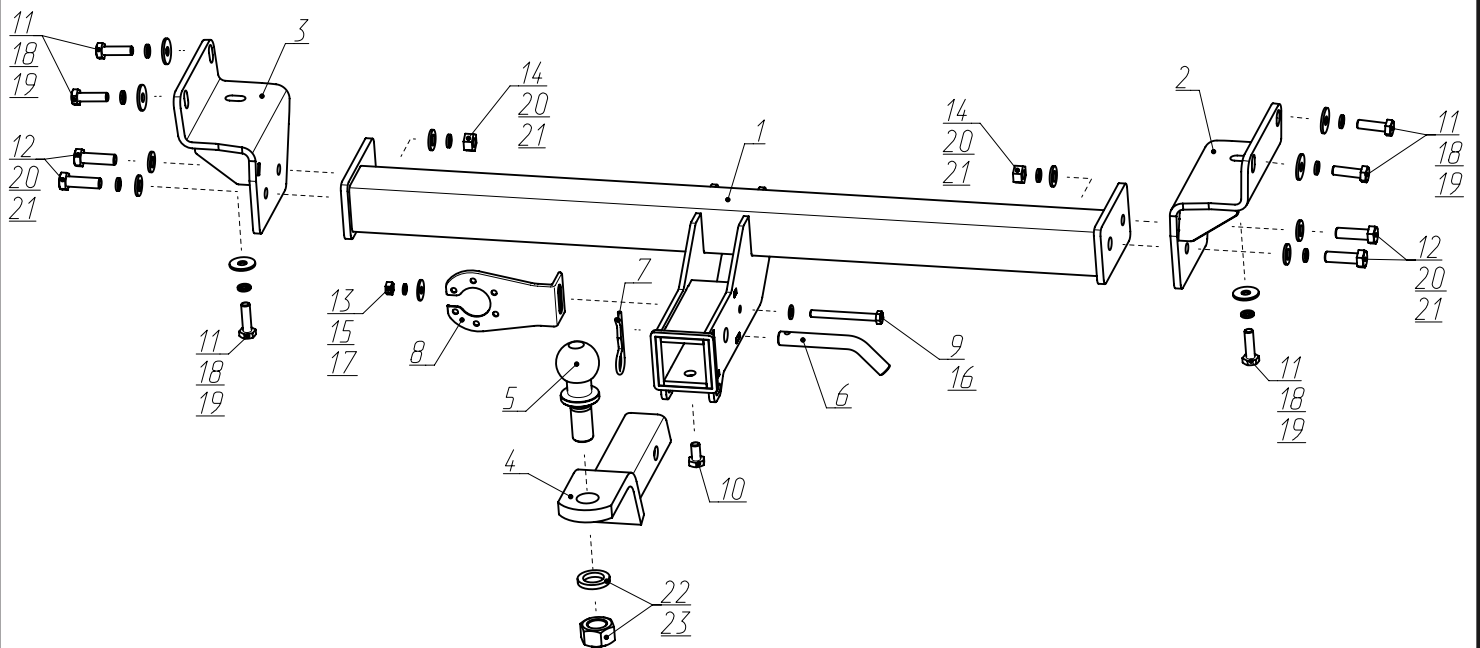

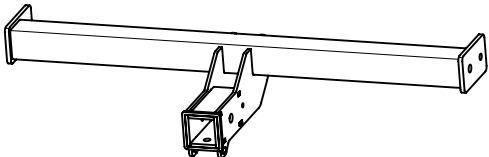

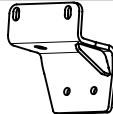
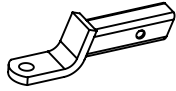
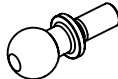

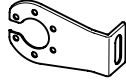

	 <p>2000 kg</p>	 <p>75 kg</p>	<p>D = 10,2 kN</p>						
<p>$D \text{ (kN)} = \frac{\text{MAX kg} \times \text{MAX kg}}{\text{MAX kg} + \text{MAX kg}} \times 0,00981$</p> 	<table border="0"> <tr> <td>Hyundai Tucson (2021-)</td> <td></td> <td><input checked="" type="checkbox"/></td> </tr> <tr> <td>KIA Sportage (2022-)</td> <td></td> <td><input checked="" type="checkbox"/></td> </tr> </table>			Hyundai Tucson (2021-)		<input checked="" type="checkbox"/>	KIA Sportage (2022-)		<input checked="" type="checkbox"/>
Hyundai Tucson (2021-)		<input checked="" type="checkbox"/>							
KIA Sportage (2022-)		<input checked="" type="checkbox"/>							

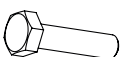

Используемый инструмент:



13 mm
19 mm
36 mm

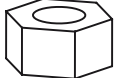

1	x1	Балка в сборе	
2	x1	Кронштейн правый	
3	x1	Кронштейн левый	
4	x1	Переходник	
5	x1	Шар	
6	x1	Штифт	
7	x1	Шплинт	
8	x1	Кронштейн под розетку	
9	x1	M8x80	
10	x1	M10x20	
11	x6	M10x1,25x35	
12	x4	M12x1,25x40	
13	x1	Гайка 8	
14	x2	Гайка 12x1,25	
15	x1	Ø 8	
16	x1	Ø 8	
17	x1	Ø 8 увел.	
18	x6	Ø 10	
19	x6	Ø 10 увел.	
20	x4	Ø 12	

21	x6	∅12	
22	x1	Гайка 24	
23	x1	∅24	

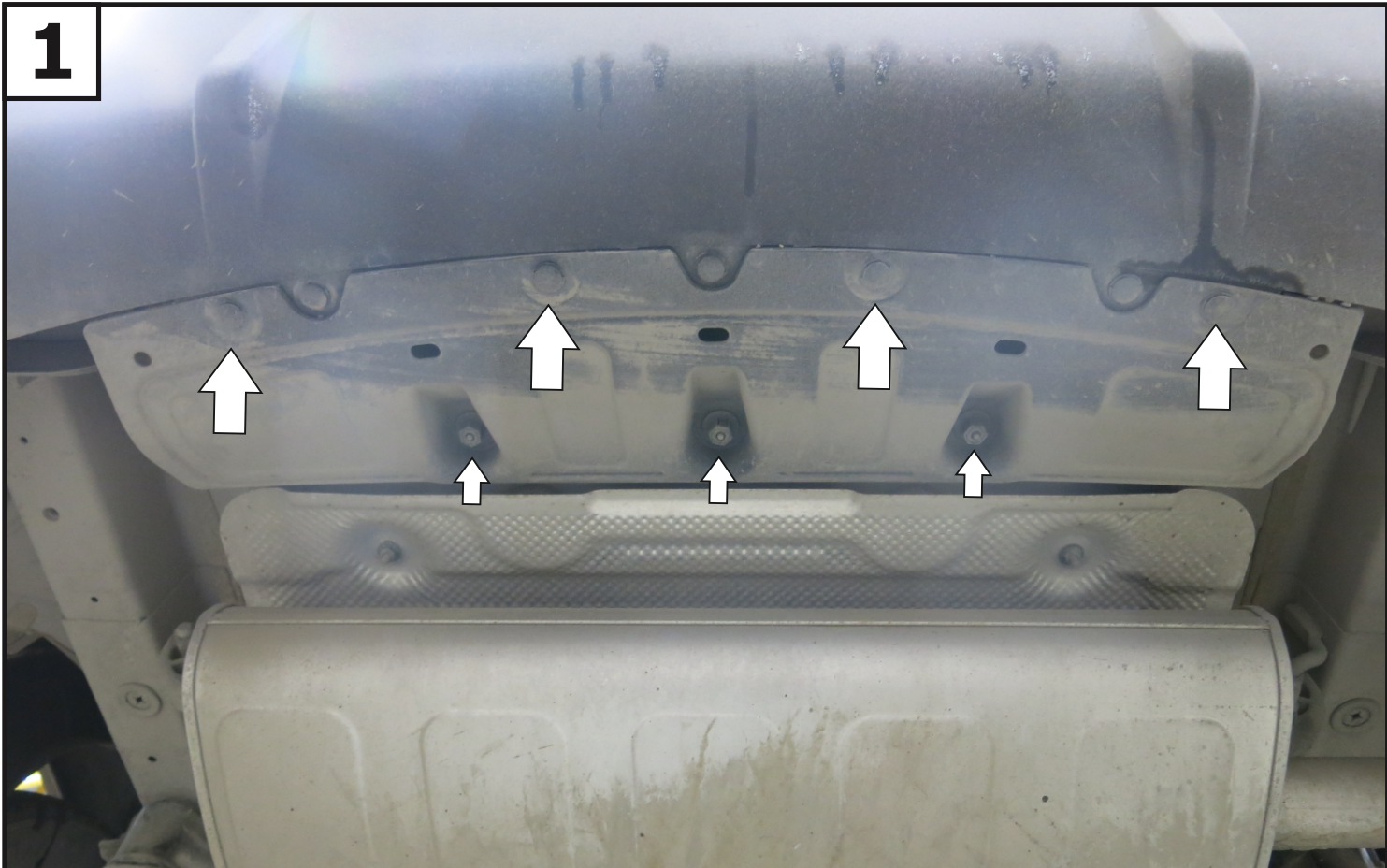

1

Перед установкой ТСУ необходимо демонтировать пыльник бампера, сняв 4 клипсы и открутив фиксаторы.



2

3

Установить кронштейн (2) на правый лонжерон автомобиля, закрепив с помощью болтов М10х1,25х35 (11), шайб 10 пруж. (18) и шайб 10 увел. (19) в штатные резьбовые отверстия.

4

Установить кронштейн (3) на левый лонжерон автомобиля, закрепив с помощью болтов М10х1,25х35 (11), шайб 10 пруж. (18) и шайб 10 увел. (19) в штатные резьбовые отверстия.

5

К установленным кронштейнам закрепить балку (1) с помощью болтов М12х1,25х40 (12), гаек М12х1,25 (14), шайб 12 пруж. (20) и шайб 12 (21) в соответствии со схемой стр. 2 .

6

Установить кронштейн под розетку (8) на балку (1) с помощью болта М8х80 (9), шайбы 8 (16), шайбы 8 пружин. (15), шайбы 8 увел. (17) и гайки 8 (13).

7

Установить переходник (4), закрепив с помощью штифта (6) и шплинта (7). Зафиксировать переходник болтом M10x20 (10) - фиксацию использовать только без нагрузки. Установить на переходник шар (5), закрепив гайкой M24 (22) с шайбой 24 пружинной (23).

8

Затянуть все резьбовые соединения.

Моменты затяжки: M8=25 Нм, M10=47 Нм, M12=81 Нм, M24=95 Нм.